

KOLDLOK[®]

Surface Mount Raised Floor Grommets



Item No. 2020



Item No. 2030



Item No. 2040

Applications

Designed to seal a variety of existing raised floor tile cutouts and allow flexibility of removing tiles without capturing cables. Item Nos. 2030 and 2040 allow for larger sealing capacities.

Based on measurements at multiple data centers, 50-80% of valuable conditioned air is not reaching the air intake of IT equipment due to unsealed floor openings. This lost air, known as bypass airflow, contributes to IT equipment hot spots, cooling unit inefficiencies, and increasing infrastructure costs. KoldLok products specifically address bypass airflow and its detrimental effects on data center cooling.

Benefits

- Increases existing cooling unit capacity
- Reduces the need to purchase additional cooling units
- Improves equipment reliability and extends equipment life
- Increases static pressure under the raised floor and improves cool air delivery through perforated tiles and floor grates
- Facilitates Cold Aisle/Hot Aisle best practices

Features

The Surface Mount Grommets facilitate re-cabling and allows tiles to be moved without capturing cables.

The Grommets integrate with the raised floor static dissipation system, providing 1 GigaOhm of resistance.

The Grommets contain no loose or partially fastened parts, which can become separated or fall through the raised floor.

The Grommets are impact resistant and durable.

KoldLok products are compliant with Directive 2002/95/EC of the European Parliament and the Council on the Restriction of the Use of Certain Hazardous Substances in Electrical and Electronic Equipment (RoHS).

Specifications

Dimensions and Tile Cutting Requirements	Inches (W x D x H)	Millimeters (W x D x H)
Overall size (Item No. 2020)	11 x 8 1/4 x 1 1/8	279 x 209 x 29
Product height above the raised floor	1 1/4 with mounting system installed	29
Maximum cutout size sealed	10 x 7 1/4	254 x 184
Usable cable area	8 1/4 x 4	210 x 102
Overall size (Item No. 2030)	12 x 11 3/4 x 1 5/16	305 x 298 x 33
Product height above the raised floor	1 7/16 with mounting system installed	37
Maximum cutout size sealed	10 x 9 3/4	254 x 248
Usable cable area	8 1/4 x 4	210 x 102
Overall size (Item No. 2040)	12 x 15 x 1 5/16	305 x 381 x 33
Product height above the raised floor	1 7/16 with mounting system installed	37
Maximum cutout size sealed	10 x 13	254 x 330
Usable cable area	8 1/4 x 4	210 x 102

Patented Sealing System

(U.S. Patent No. 6,632,999 and International patents pending) Multi layer, opposing and interwoven filaments consisting of:

- 0.010 inch diameter upper filaments
- 0.020 inch diameter lower filaments
- Approximately 25,000 filaments per Grommet
- Static dissipative properties
- Premium-grade nylon Type 6 ensuring flexibility and self-sealing recovery

Sealing Effectiveness

- 100% bypass-airflow sealing in areas undisturbed by cable penetrations at static pressures up to 0.10 inches of water column
- 100% bypass-airflow sealing with four 1/2 inch cables penetrating the Grommet at the static pressure required to cool up to 3 kW/cabinet
- 96% bypass-airflow sealing with four 1/2 inch cables penetrating the Grommet at a static pressure of 0.10 inches of water column

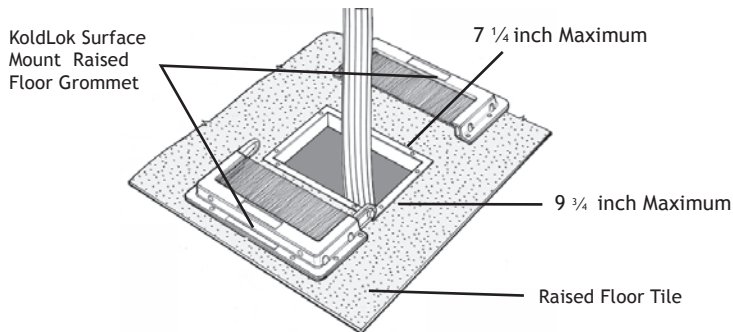

Grommet Frame

The frame is molded from durable polypropylene. The frame consists of two, interlocking halves.

Finish: Black

Floor Mounting System

Custom adhesive mounting kit consisting of:

- Single-sided, pressure sensitive foam with adhesive backing
- Double-sided, pressure sensitive foam with adhesive backing
- Polyethylene foam buttons for static dissipation
- All foam components are non-particulating

